

# FICHE TECHNIQUE

---

---

# TECHNICAL SHEET



# QUANTICA 500

## CARACTÉRISTIQUES TECHNIQUES

CONCEPTION	Corps en fonte d'aluminium, verre plat trempé, résistance aux chocs IK 08
FINITION	Peinture polyester selon nuancier RAL
PROTECTION	IP66
ISOLATION	Classe 1 ou 2
FIXATION	Montage latéral : tube $\varnothing$ 60 mm Montage en top : tube $\varnothing$ 60 - 76 mm Montage sommital : PG 27 mâle

## DIMENSIONS, POIDS, PUISSANCE

DIMENSIONS	En top : 630 x 140 mm Suspendu : $\varnothing$ 530 x 140 mm Latéral : 610 x 140 mm
POIDS	Suspendue : 8,5 kg / Latérale : 7,5 kg
NOMBRE DE LED	16 - 32 - 48
PUISSANCE LED	17 à 159 W

## TECHNICAL CHARACTERISTICS

CONCEPTION	Die cast aluminium body, flat hardened glass, shock resistance IK 08
FINISH	Polyester paint according to RAL color chart
PROTECTION	IP66
INSULATION	Class 1 or 2
FIXING	Side fixing assembly : $\varnothing$ 60 male pipe / On top assembly : 60 - 76 male pipe / Hanging assembly : Male 27 PG

## SIZE, WEIGHT, WATTAGE

SIZE	On top : 630 x 140 mm Hanging : $\varnothing$ 530 x 140 mm Side : 610 x 140 mm
WEIGHT	Hanging : 8,5 kg / Side fixing : 7,5 kg
NUMBER OF LED	16 - 32 - 48
LED WATTAGE	17 to 159 W

CURVED POLE / MÂT INCURVÉ

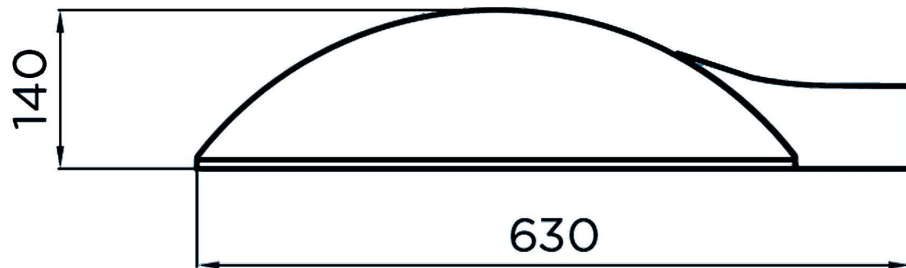

SUSPENDED / SUSPENDUE

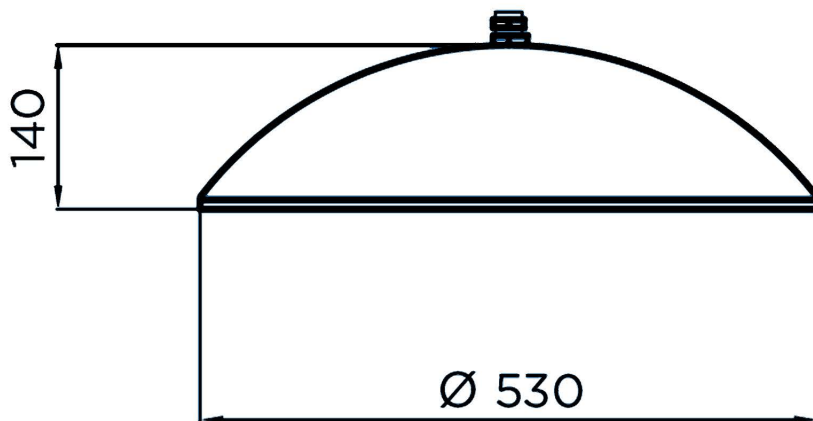

LAYING MOUNTED / LATERAL

